



MPI Excellence[®] System

The commitment to excellence
that we all seek





MPI Excellence® System	4
Advantages	6
Internal connection conical seal	10
- Prosthetic components CM	12
- Prosthetic components for digital solutions	24
Abutment screws	26
Surgical material	27
- Dental cases	28
- Surgical drills	31
- Screwdrivers and surgical instruments	32
General information	36
- Packaging opening instructions	37
- International implantable product card	38
- Label symbology	39
- Recommended implant placement	40
- Quality and general conditions of sale	41

MPI
Excellence[®]
System

Advantages MPI Excellence®

The MPI Excellence® implant system is characterized by its conical body. The implant achieves a high primary stability by condensing the bone through the osteotome effect. Due to the design of its threads it is ideal for post-extraction surgeries.

Coronal Design

The micro thread in the coronal part reduces the marginal implant bone loss and benefits the implant with an improved fatigue resistance.

Thread Design

The double entrance of the threads enables an easy and continuous insertion of the implant.

The active and self-tapping threads increasing in the apical direction condense the bone gradually, obtaining high initial stability quotients in any type of bone densities.

Apical Design

The two helical cutting sides and its conical apical design give the clinician the possibility to change the direction of the implant during the placement, boosting notably the success rate of the surgeries.

INTERNAL
CONNECTION
CONICAL
SEAL

Conical Seal Design

The double internal hexagon permits a fast and adjusted insertion of the prosthetic components, achieving a completely hermetic mechanical closing and tightness.

The mono-block behaviour prevents bacterial filtrations and strengthens the design avoiding the physical fatigue when they work as a set.

Leeway to Manoeuvre and React

In order to be able to react and stop bacterial colonisations in early stages, the coronal neck has no surface treatment.

Decontamination processes are more effective and faster and a minimization of the bone loss is granted.

Surface Treatment Integratec®

Double superficial treatment. Its macro- and microstructure act in favour of the adhesion of the osteoblasts, responsible for the formation of the bone. The healing periods are reduced and the early bone-to-implant contact is boosted.

High Performance Titanium

The commercially pure Titanium Grade IV cold drawn material used for the production of the implants, reinforces the implant structure hardness by 20%. This characteristic permits higher torque values during the insertion of the implant.

Material of German origin.

Internal Connection Conical Seal

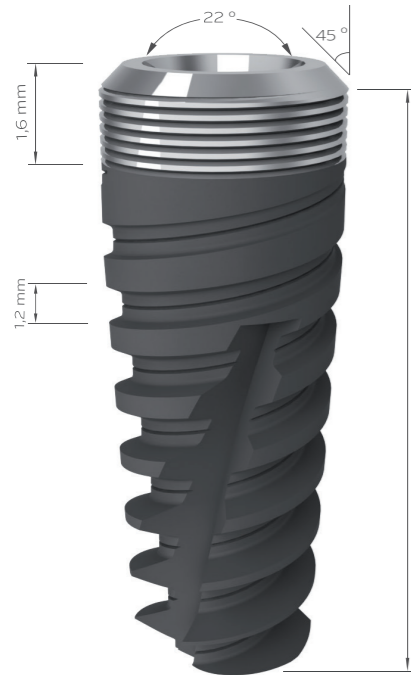

Product features

- The micro thread in the coronal part benefits the implant with an optimal distribution of the functional loads and reduces the marginal implant bone loss.
- Tapered body and wide thread step: permit an easy insertion, as well as an improvement of the primary stability through constant bone condensing during the insertion.
- The width of the self-tapping implant threads increase progressively from the apical to the coronal part.
- Superficial treatment Integratec®.
- Sharp helical cutting sides enable the implant to penetrate into reduced implant beds.
- Direct surgery through the conical handpiece connectors.
- Reinforced implant structure by the use of Titanium Grade IV cold drawn bars.
- Cover screw included in the implant package.
- Indicated for all types of bone densities, especially type IV and post-extraction surgeries.
- Maximum torque recommended: 80 N·cm.

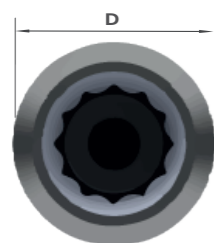

		D - Diameter (mm)			
IECM		Ø 3,5	Ø 3,75	Ø 4,3	Ø 5
H - Length (mm)	8,5	IECM38	IECM378	IECM48	-
	10	IECM310	IECM3710	IECM410	IECM510
	11,5	IECM311	IECM3711	IECM411	IECM511
	13	IECM313	IECM3713	IECM413	IECM513
	15	IECM315	IECM3715	IECM415	IECM515
		M 1,6			M 2,0



Cover Screw

- Made of Titanium Grade V with anodizing treatment.
- Use with screwdriver hexagonal manual Ø 1,2 mm (SDHM 121 / SDHM 122).
- Maximum torque recommended: 10 N·cm.

	Ø 3,5 / Ø 3,75 / Ø 4,3	Ø 5
0 mm	CM594	CM595

Drilling Sequence IECM



	Implant diameter (mm)			
	Ø 3,5	Ø 3,75	Ø 4,3	Ø 5
Lance Drill	● ● ● ●	● ● ● ●	● ● ● ●	● ● ● ●
Straight Drill Ø 2,0 mm	● ● ● ●	● ● ● ●	● ● ● ●	● ● ● ●
Conical Drill Ø 3,5 mm	● ● ● ●			
Conical Drill Ø 3,75 mm		● ● ● ●		
Conical Drill Ø 4,3 mm			● ● ● ●	
Conical Drill Ø 5 mm				● ● ● ●
Pilot Drill Ø 3,5 mm	● *2 marks ● *1 marks			
Pilot Drill Ø 3,75 mm		● *2 marks ● *1 mark		
Pilot Drill Ø 4,3 mm			● *2 marks ● *1 mark	
Pilot Drill Ø 5 mm				● *2 marks ● *1 mark
Tap	●	●	●	●

● BONE TYPE IV
 ● BONE TYPE III
 ● BONE TYPE II
 ● BONE TYPE I
 * OPTIONAL

MPI Excellence[®]
Systems

Internal
Connection
Conical Seal



Healing Abutment Straight

- Made of Titanium Grade V.
- Maximum torque recommended 10 N·cm.
- Use with screwdriver 1,2 mm (SDHM121 / SDHM122).

	Ø 3,5 / Ø 3,75 / Ø 4,3	Ø 5
2 mm	EXC701	-
3 mm	EXC702	EXC706
4 mm	EXC703	-
5 mm	EXC704	EXC707
7 mm	EXC705	EXC708

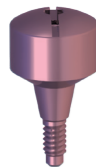

Healing Abutment Aesthetic

- Made of Titanium Grade V.
- Maximum torque recommended 10 N·cm.
- Use with screwdriver 1,2 mm (SDHM121 / SDHM122).

	Ø 3,5 / Ø 3,75 / Ø 4,3	Ø 5
	Ø 4,3 - Ø 5	Ø 5 - Ø 6
3 mm	EXC709	EXC711
5 mm	EXC710	EXC712



Temporary Abutment

- Made of PEEK.
- Recommended: hexagonal abutment for single restorations and cylindrical abutment for multiple restorations.
- Used in temporary restorations.
- Abutment screw not included. CM535 (Ø 3,5 / Ø 4) ó CM 536 (Ø 5)

	Ø 3,5 / Ø 3,75 / Ø 4,3	Ø 5
Hexagonal	CM523	CM524
Cylindrical	CM525	CM526





Impression Coping Open Tray

- Made of stainless steel.
- Maximum torque recommended 10 N·cm.
- Use with screwdriver 1,2 mm (SDHM121 / SDHM122).

	Ø 3,5 / Ø 3,75 / Ø 4,3	Ø 5
Straight	CM541	CM542
	Ø 3,5 / Ø 3,75 / Ø 4,3 - Ø 5	Ø 5 - Ø 6
Aesthetic	CM543	CM544



Impression Coping Closed Tray

- Made of stainless steel.
- Maximum torque recommended 10 N·cm.
- For use in multiple restorations.

	Ø 3,5 / Ø 3,75 / Ø 4,3	Ø 5
Straight	CM545	CM546
	Ø 3,5 / Ø 3,75 / Ø 4,3 - Ø 5	Ø 5 - Ø 6
Aesthetic	CM547	CM548



Implant Analog

- Made of stainless steel.

	Ø 3,5 / Ø 3,75 / Ø 4,3	Ø 5
	EXC749	EXC750

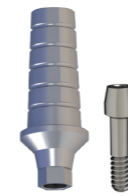

Straight Abutment

- Made of Titanium Grade V.
- Maximum torque recommended 30 N·cm.
- For direct implant restorations.
- For cement-retained prosthesis.
- Recommended that the gum height should be superior than the shoulder of the abutment.
- Served with the abutment screw CM535 (Ø 3,5 / Ø 4) ó CM 536 (Ø 5).

	Ø 3,5 / Ø 3,75 / Ø 4,3	Ø 5
1 mm	CM551	CM555
2 mm	CM552	CM556
3 mm	CM553	CM557
4 mm	CM554	CM558



Angled Abutment

- Made of Titanium Grade V.
- Maximum torque recommended 30 N·cm.
- For direct implant restorations.
- For cement-retained prosthesis.
- Recommended that the gum height should be superior than the shoulder of the abutment.
- Served with the abutment screw CM535 (Ø 3,5 / Ø 4) ó CM 536 (Ø 5).

	Ø 3,5 / Ø 3,75 / Ø 4,3	Ø 5
Angulation 15°	CM559	CM561
Angulation 25°	CM560	CM562



Cr-Co Base Castable Abutment

- Maximum torque recommended 30 N-cm.
- For direct implant restorations. To use with screw-retained prostheses.
- Recommended hexagonal abutment for single restorations.
- All non-rotating castable abutments are in black color and the rotating castable abutments in white color.
- Served with the abutment screw CM535 (Ø 3,5 / Ø 4) ó CM 536 (Ø 5).

	Ø 3,5 / Ø 3,75 / Ø 4,3	Ø 5
Hexagonal	CM575	CM576
Cylindrical	CM577	CM578



Cr-Co Base Angled Castable Abutment

- Maximum torque recommended 20 N-cm.
- To use with screw-retained prostheses.
- Served with dynamic screw (CM579 / CM580).

	Ø 3,5 / Ø 3,75 / Ø 4,3	Ø 5
Hexagonal 17°	CM585	CM586
Hexagonal 30°	CM587	CM588
Cylindrical 17°	CM581	CM582
Cylindrical 30°	CM583	CM584



MPI Pack

- Composed of: Impression Coping, Implant Analog, Cr-Co Base Castable Abutment and Abutment Screw.

	Ø 3,5 / Ø 3,75 / Ø 4,3	Ø 5
Hexagonal	MPI PACK CMS HEX.	MPI PACK CML HEX.
Cylindrical	MPI PACK CMS CIL.	MPI PACK CML CIL.

Transepithelial System



Transepithelial Straight Abutment

- Made of Titanium Grade V.
- Maximum torque recommended 30 N-cm.
- For multiple restorations.

	Ø 3,5 / Ø 3,75 / Ø 4,3	Ø 5
1,5 mm	EXC765	EXC769
2,5 mm	EXC766	EXC770
3,5 mm	EXC767	EXC771
4,5 mm	EXC768	EXC772

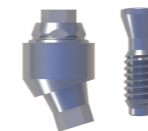

Transepithelial Angled Abutment

- Made of Titanium Grade V.
- Maximum torque recommended 30 N-cm.
- For use in multiple restorations.
- Allows to correct disparelisms between implants.
- Indicated for Ø 3,5 / Ø 3,75 / Ø 4,3 mm implants.
- Served with definitive screw (TRO01).

	Angulation 17°	Angulation 30°
2,5 mm	CM569	-
3,5 mm	CM570	CM571
4,5 mm	-	CM572



Healing Cap

TRO07



Hand Piece Connector

TRO10

Transepithelial System

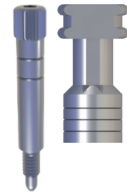

Impression Coping Open Tray

- Made of stainless steel.
- Maximum torque recommended 10 N·cm.
- Use with screwdriver 1,2 mm (SDHM121 / SDHM122).

TR002



Impression Coping Closed Tray

- Made of stainless steel.
- Maximum torque recommended 10 N·cm.
- Indicated for multiple restorations.

TR003



Transepithelial Analog

- Made of stainless steel.

Hexagonal	TR004A
Cylindrical	TR004



Temporary Abutment

- Made of PEEK.
- For multiple restorations.
- Short screw M 1,4 not included (TRO08 / TRO09).

TR006



Straight Abutment

- Made of Titanium Grade V.
- For multiple restorations.
- Short screw M 1,4 not included (TRO08 / TRO09).

TR011



Castable Abutment

- Use with screw-retained prostheses.
- Indicated for multiple restorations.
- Short screw M 1,4 not included (TRO08 / TRO09).

TR005



Cr-Co Base Castable Abutment

- Use with screw-retained prostheses.
- Recommended hexagonal abutment for single restorations.
- All non-rotating castables are in black color for easily identify and the rotating ones in white color.
- Short screw M 1,4 not included (TRO08 / TRO09).

Hexagonal	TR015A
Cylindrical	TR015



Short screw M 1,4

- Made of Titanium Grade V.
- Maximum torque recommended 10 N·cm.
- For transepithelial uniblock abutment, use the TRO09 screw.
- For transepithelial angled abutment, use the TRO08 screw.

2 mm	TR008
3 mm	TR009



Ti-Base

- Manufactured in Titanium Grade V and Titanium Nitride (TiN) coating.
- Short screw not included (TRO08 / TRO09).
- Allows angulation with dynamic screw up to 30°.

Hexagonal	TR013A
Cylindrical	TR013



Digital Transepithelial Analog

Hexagonal	TR012A
Cylindrical	TR012



Scanbody

TR014

Locator® System



Locator® Abutment

- Threaded abutment Locator® directly to the implant.
- Indicated for overdentures.
- Tolerates implant divergences between 20° y 40°.
- Use with the Locator® Core Tool (LO8393).

	∅ 3,5 / ∅ 3,75 / ∅ 4,3	∅ 5
1 mm	LO8115	LO8686
2 mm	LO8116	LO8687
3 mm	LO8117	LO8688
4 mm	LO8118	LO8689
5 mm	LO8119	LO8690



Impression Coping

LO8505



Analog

LO8530



Standard Range Male Processing Package

Allows divergences up to 20°.

LO8519



Extended Range Male Processing Package

Allows divergences up to 40°.

LO8540

Retention Replacement Male



White (2,27 Kgf)	LO8524
Pink (1,36 Kgf)	LO8527
Blue (0,68 Kgf)	LO8529
Green (1,36 - 1,81 Kgf)	LO8547
Red (0 - 0,68 Kgf)	LO8548

Locator® Core Tool



LO8393

Locator® Bar Attachment System



Drill & tap



Cast to

Bar Abutment Thread (pack 2 units)	LO8589
Castable Threaded Insert (pack 10 units)	LO8014
Bar Male Processing Package (pack 2 units)	LO8028
Cast-to Abutment (pack 2 units)	LO8586
Bar Male Processing Package (pack 2 units)	LO8028

Equator® System



Equator® Abutment

- Threaded abutment directly to the implant.
- Indicated for overdentures.
- Tolerates an implant divergence up to 50°.
- Use with Equator® tools (EQ1001 / EQ1009).
- Standard retention replacement male processing package included in the Equator® abutment package.

Internal Connection Conical Seal

	∅ 3,5/ ∅ 3,75 / ∅ 4,3	∅ 5
1 mm	EQCM341	-
2 mm	EQCM342	EQCM52
3 mm	EQCM343	EQCM53
4 mm	EQCM344	EQCM54
5 mm	EQCM345	EQCM55
6 mm	EQCM346	-
7 mm	EQCM347	-



Impression Coping

EQ1002



Analog

EQ1010

Retention Replacement Male



Black	EQ1003
Purple (2,7 kg)	EQ1005
Pink (1,2 kg)	EQ1006
Yellow (0,6 kg)	EQ1007
White (1,8 kg)	EQ1008

Equator® Tools

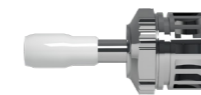

EQ1001

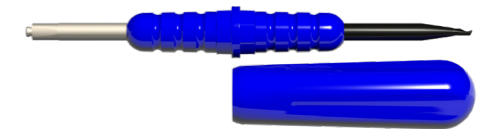

EQ1009

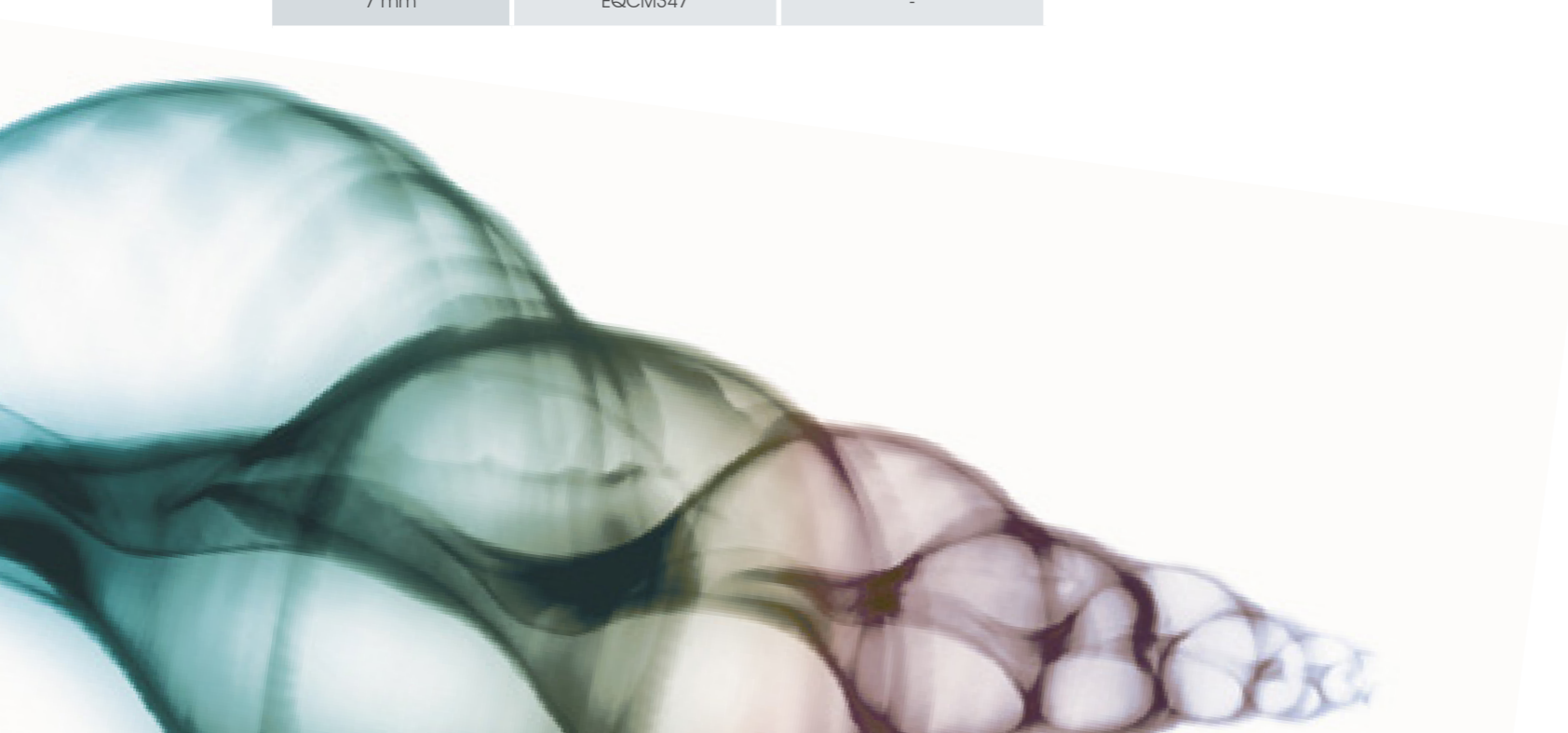

CAD-CAM System



Ti-Base

- Made of Titanium Grade V with Titanium Nitride (TiN).
- Abutment screw (CM535 / CM536) included.
- Allows angulation with dynamic screw up to 30°.

	Ø 3,5 / Ø 3,75 / Ø 4,3	Ø 5
Hexagonal	CM600	CM601
Hexagonal 2 mm	CM600HG2	CM601HG2
Hexagonal 3 mm	CM600HG3	CM601HG3
Cylindrical	CM602	CM603
Cylindrical 2 mm	CM602HG2	CM603HG2
Cylindrical 3 mm	CM602HG3	CM603HG3



Dynamic Screw

- Maximum torque recommended 20 N-cm.
- Use with angled screwdriver KD9142.

Ø 3,5 / Ø 3,75 / Ø 4,3	Ø 5
CM579	CM580



Scanbody

- Made of Titanium Grade V.
- Surface treatment to avoid reflection.
- Abutment screw (CM535 / CM536) included.

	Ø 3,5 / Ø 3,75 / Ø 4,3	Ø 5
Hexagonal	CM610	CM611



Digital Analog

- Made of stainless steel.

	Ø 3,5 / Ø 3,75 / Ø 4,3	Ø 5
Hexagonal	CM612	CM613



Dynamic Screwdriver

- Use with dynamic screw (CM579 / CM580).



20 mm	KD9142S
25 mm	KD9142M
30 mm	KD9142L

Download our libraries at www.mpimplants.com



Surgical Material

Conical Seal			
Definition	Reference	Implant Diameter	Recommended Torque
 Abutment screw hex. 1,2 mm	CM535	Ø 3,5 / Ø3,75 / Ø 4,3 mm	30 N-cm
	CM536	Ø 5 mm	30 N-cm
 Abutment screw hex. 1,2 mm with DLC treatment	CM535 DLC	Ø 3,5 / Ø3,75 / Ø 4,3 mm	30 N-cm
	CM536 DLC	Ø 5 mm	30 N-cm
 Laboratory screw	CM537	Ø 3,5 / Ø3,75 / Ø 4,3 mm	20 N-cm
	CM538	Ø 5 mm	20 N-cm
 Definitive gold screw	CM539	Ø 3,5 / Ø3,75 / Ø 4,3 mm	30 N-cm
	CM540	Ø 5 mm	30 N-cm
 Dynamic screw	CM579	Ø 3,5 / Ø3,75 / Ø 4,3 mm	25 N-cm
	CM580	Ø 5 mm	25 N-cm

Transepithelial System			
Definition	Reference	Implant Diameter	Recommended Torque
 Definitive screw CM transepithelial	TR001 CM	Ø 3,5 / Ø 3,75 / Ø 4,3 mm	30 N-cm
		Ø 5 mm	
 Short screw M 1.4 for angled transepithelials (2 mm)	TR008	-	10 N-cm
 Short screw M 1.4 for angled transepithelials (3 mm)	TR009	-	10 N-cm

Dental Case Combined

MPI Privilege®, MPI Excellence®, MPI All-In®



Reference	Description
DC68	Dental Case Combined
IDCC68	Insert Dental Case Combined

Content of Dental Case		
Dental case	Hand piece connector	Tap conical Ø 5 mm
Lance drill	Ratchet extensor long	Conical directional indicators
Drill extensor	Ratchet extensor short	Hand piece connector conical Ø 3,5 / Ø 4 mm
Initial drill Ø 2x15 mm	Conical drill Ø 3,5 mm	Hand piece connector conical Ø 5 mm
Drill Ø 2,75 mm	Conical drill Ø 3,75 mm	Ratchet extensor Ø 3,5 / Ø 4 mm
Drill Ø 3 mm	Conical drill Ø 4,3 mm	Ratchet extensor Ø 5 mm
Step drill Ø 3,25 / Ø 3,60 mm	Conical drill Ø 5 mm	Screwdriver hexagonal manual 1,0 mm
Step drill Ø 4,25 / Ø 4,60 mm	Pilot drill conical Ø 3,5 mm	Screwdriver hexagonal manual 1,2 mm
Countersink	Pilot drill conical Ø 3,75 mm	Motor screwdriver hexagonal 1,2 mm short
Pilot drill	Pilot drill conical Ø 4,3 mm	Motor screwdriver hexagonal 1,2 mm long
Tap Ø 3 mm	Pilot drill conical Ø 5 mm	Wrench standard
Tap Ø 4 mm	Tap conical Ø 3,5 mm	Open holding key
Tap Ø 5 mm	Tap conical Ø 3,75 mm	Implant depth gauge
Straight directional indicators	Tap conical Ø 4,3 mm	Insert IDCC68

MPI Excellence® and MPI All-In® Dental Case



Reference	Description
DC36	Dental Case Small
IDCE36	Insert Dental Case MPI Excellence® Small

Content of Dental Case		
Lance drill	Hand piece connector conical Ø 3,5 / Ø 3,75 / Ø 4,3 mm	Screwdriver hexagonal manual 1,0 mm long
Initial drill Ø 2 x 15 mm	Hand piece connector conical Ø 5 mm	Ratchet extensor conical small long Ø 3,5 / Ø 3,75 / Ø 4,3 mm
Tap conical Ø 3,5 mm	Pilot drill conical Ø 3,5 mm	Ratchet extensor conical large long Ø 5 mm
Tap conical Ø 3,75 mm	Pilot drill conical Ø 3,75 mm	Screwdriver hexagonal manual 1,2 mm long
Tap conical Ø 4,3 mm	Pilot drill conical Ø 4,3 mm	Wrench standard
Tap conical Ø 5 mm	Pilot drill conical Ø 5 mm	Insert IDCE36

MPI Drill Stopper Case

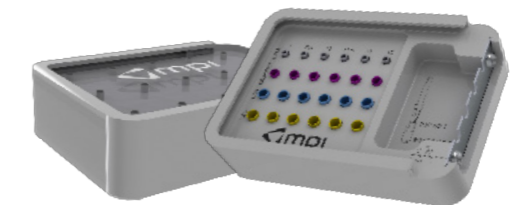

Reference	Description
STDC Case	Stoppers Drills Conical Case

MPI Excellence® and MPI All-In® Dental Case Conical Drills



Reference	Description
DC001	Dental case conical drills
IDC001	Insert D.C conical drills

Content of Dental Case			
Dental case conical drills	Pilot drill conical Ø 3,5 mm	Direct. indicator conical Ø 3,5 mm	Screwdriver hexagonal manual 1,2 mm short
Lance drill DLC	Pilot drill conical Ø 3,75 mm	Direct. indicator conical Ø 3,75 mm	Screwdriver hexagonal manual 1,2 mm long
Drill extensor	Pilot drill conical Ø 4,3 mm	Direct. indicator conical Ø 4,3 mm	Motor screwdriver hexagonal 1,2 mm short
Drill DLC Ø 2x15 mm	Pilot drill conical Ø 5 mm	Direct. indicator conical Ø 5 mm	Motor screwdriver hexagonal 1,2 mm long
Conical drill Ø 3,5 mm	Tap Ø 3,5 mm	Hand piece connector conical Ø 3,5/4 mm	Wrench screwdriver hexagonal 1,2 mm short
Conical drill Ø 3,75 mm	Tap Ø 3,75 mm	Hand piece connector conical Ø 5 mm	Wrench screwdriver hexagonal 1,2 mm long
Conical drill Ø 4,3 mm	Tap Ø 4,3 mm	Ratchet connector conical Ø 3.5/4 mm	Torque wrench
Conical drill Ø 5 mm	Tap Ø 5 mm	Ratchet connector conical Ø 5 mm	Insert D.C conical drills

Surgical Drills

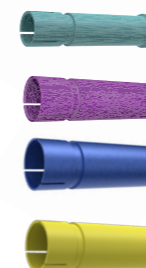
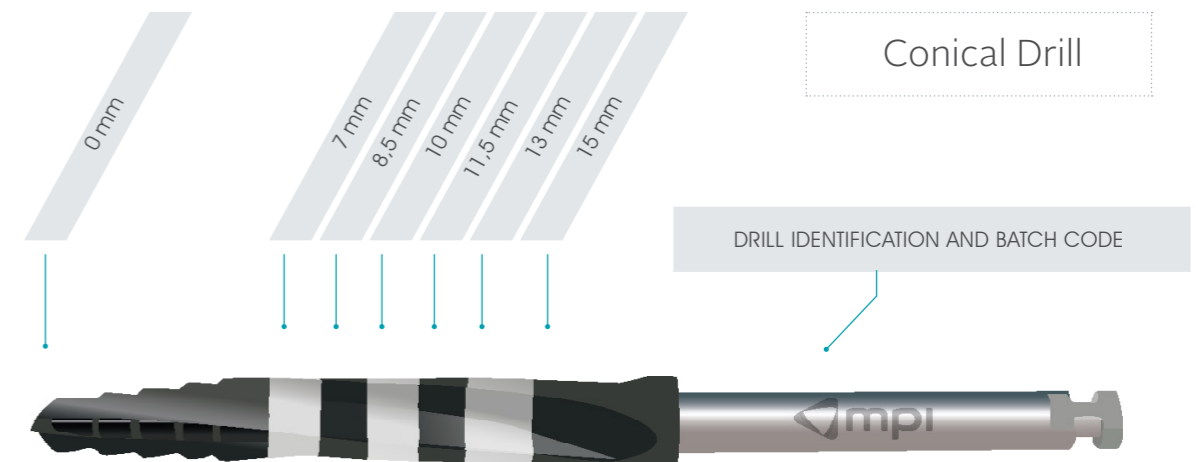

DIAMETER Ø	(mm) LENGHT	STOPPERS DRILLS			
		Ø 2	Ø 3	Ø 4	Ø 5
7		STDP27	STDC37	STDC47	STDC57
8,5		STDP28	STDC38	STDC48	STDC58
10		STDP210	STDC310	STDC410	STDC510
11,5		STDP211	STDC311	STDC411	STDC511
13		STDP213	STDC313	STDC413	STDC513
15		STDP215	STDC315	STDC415	STDC515



INITIAL DRILL	
DIAMETER	REFERENCE
Ø 1,9 mm	RD1910
-	LD3310 DLC
-	LD3317
Ø 2,0 mm	D215



CONICAL DRILLS	
DIAMETER	REFERENCE
Ø 3,5 mm	CD3
Ø 3,75 mm	CD37
Ø 4,3 mm	CD4
Ø 5 mm	CD5



PILOT DRILLS / COUNTERSINK	
DIAMETER	REFERENCE
Ø 3,5 mm	PDC3
Ø 3,75 mm	PDC37
Ø 4,3 mm	PDC4
Ø 5 mm	PDC5



TAPS	
DIAMETER	REFERENCE
Ø 3,5 mm	TAPC3
Ø 3,75 mm	TAPC37
Ø 4,3 mm	TAPC4
Ø 5 mm	TAPC5

DIRECTIONAL INDICATORS



Directional indicator conical Ø 3,5 mm	DIC3
--	------



Directional indicator conical Ø 3,75 mm	DIC37
---	-------



Directional indicator conical Ø 4,3 mm	DIC4
--	------



Directional indicator conical Ø 5 mm	DIC5
--------------------------------------	------



Gingival depth gauge Ø 3,5 / Ø 3,75 / Ø 4,3 mm	GDG 34
--	--------



Gingival depth gauge Ø 5 mm	GDG 5
-----------------------------	-------

HAND PIECE CONNECTORS



Hand piece connector Ø 3,5 / Ø 3,75 / Ø 4,3 mm short	EXC900
--	--------



Hand piece connector Ø 3,5 / Ø 3,75 / Ø 4,3 mm long	EXC901
---	--------



Hand piece connector Ø 5 mm short	EXC902
-----------------------------------	--------



Hand piece connector Ø 5 mm long	EXC903
----------------------------------	--------

EXTENSORS



Drill extensor	DEP010
----------------	--------



Ratchet extensor Ø 3,5 / Ø 3,75 / Ø 4,3 mm short	EXC910
--	--------



Ratchet extensor Ø 3,5 / Ø 3,75 / Ø 4,3 mm long	EXC911
---	--------



Ratchet extensor Ø 5 mm short	EXC912
-------------------------------	--------



Ratchet extensor Ø 5 mm long	EXC913
------------------------------	--------

SCREWDRIVERS

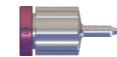

Screwdriver hexagonal manual 1,0 mm short	SDHM101
---	---------



Screwdriver hexagonal manual 1,0 mm long	SDHM102
--	---------



Screwdriver hexagonal manual 1,2 mm short	SDHM121
---	---------



Screwdriver hexagonal manual 1,2 mm long	SDHM122
--	---------



Screwdriver laboratory 1,2 mm	SDLB
-------------------------------	------



Screwdriver flat manual	SDFM010
-------------------------	---------



Motor screwdriver hexagonal 1,2 mm short	MSD010
--	--------



Motor screwdriver hexagonal 1,2 mm long	MSD020
---	--------



Screwdriver for wrench hexagonal 1,2 mm short	SDWR121
---	---------



Screwdriver for wrench hexagonal 1,2 mm long	SDWR122
--	---------



Angled system screwdriver	20 mm	KD9142S KD9142M KD9142L
	25 mm	
	30 mm	

SURGICAL TOOLS



Implants depth gauge	IDG 010
----------------------	---------



Open holding key	OHK 010
------------------	---------



Wrench standard	WST 010-2
-----------------	-----------



Torque wrench	WST 020
---------------	---------



Bone cutting system	Ø 3,5 mm	BCS 3 BCS 4 BCS 5
	Ø 4 mm	
	Ø 5 mm	

General Information

Packaging Opening Instructions

Designed for easy identification of each implant. According to the color of the cardboard box, we can find:

- Purple packaging: Implant MPI Excellence® CM



Inside the cardboard box there are the instructions for use, the international implantable product card and the dental implant blister.



1 Remove the blister from the box. Check that the blister and the label are intact and that the irradiation label is red.

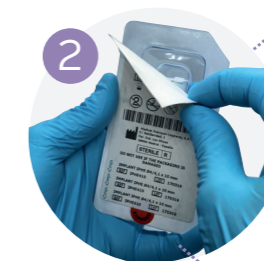

2 Remove the Tyvek® from the blister. Reserve patient labels for the patient history and international implantable product cards.

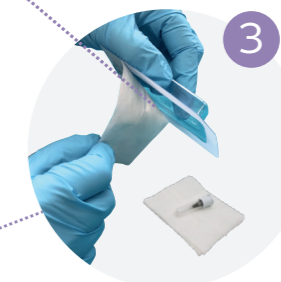

3 Deposit the dental implant on a sterile surface.



4 Remove the white cap from the tube.



5 Attach the H/P CONNECTOR to the dental implant and place according to surgical criteria.



6 Inside the cap is the cover screw.



7 With the motor or manual screwdriver, remove the cover screw from the cap and thread it on the dental implant.

International Implantable Product Card

MPI will deliver with each of its implantable products, an international implantable product card.

This card contains the following pre-printed information:

- MD: Medical device to which the card belongs
- UDI: Unique product identifier.

The user must stick a patient label (included on the product label) on each of the two boxes identified with:

- LOT / UDI-DI.

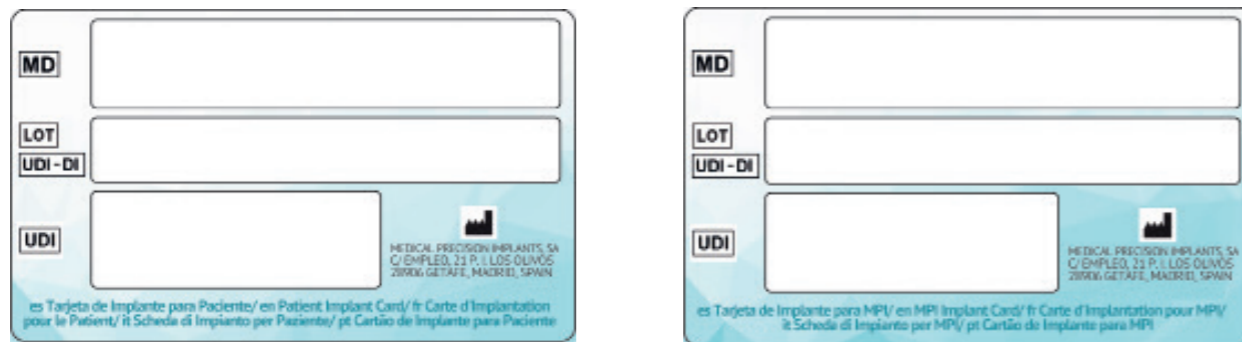

On the back of the card, the user must fill in the following information with the patient's information:

- Patient name (Patient ID)
- Record number (Patient number)
- Implementation date
- Name of the medical care center.

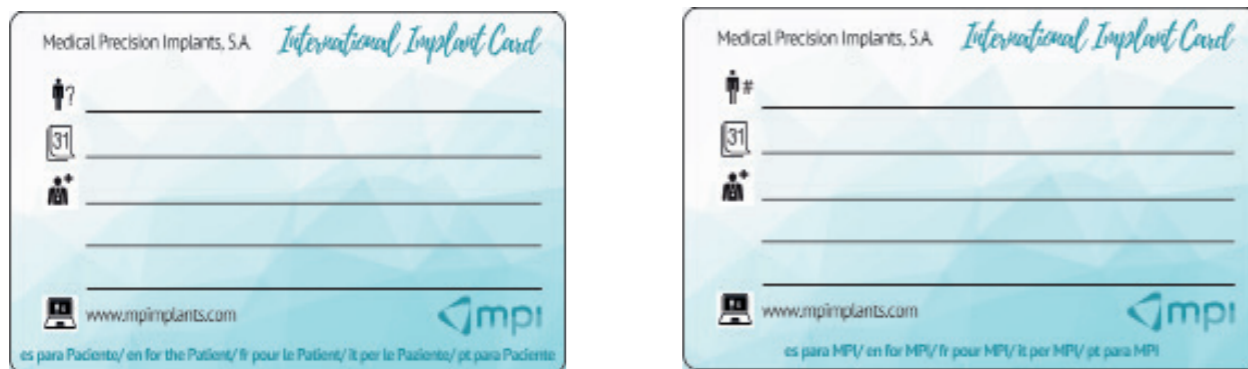

The international implantable product card marked with:

- "for the Patient", must be given to the patient and
- "for MPI", must be returned to MPI by the medical care center.

Label Symbolology

Label:

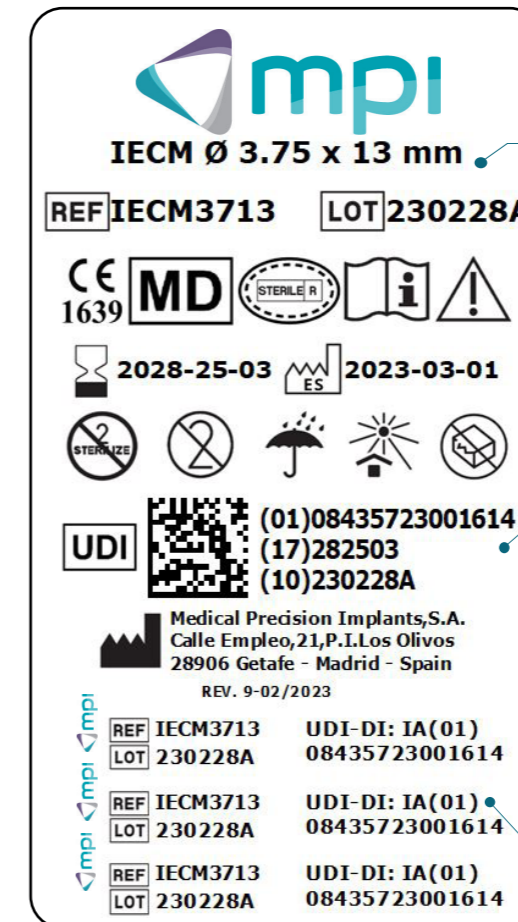

Dental implant description and measurements are indicated:
• IECM: MPI Excellence® System

UDI - DataMatrix
(01) UDI-DI
(17) Expiration date (YYMMDD)
(10) Batch number

Patient labels indicating reference, batch code and UDI-DI.

Symbolology:

	Manufacturer.		Caution.
	Country of manufacture with the two-letter country code defined in the Standard ISO 3166-1. The date of manufacture can be added adjacent to the symbol.		UDI-DI Data matrix: (01) UDI-DI / (17) Expiration date (YYMMDD) / (10) Batch number.
	Batch code.		CE symbol with the notified body number 1639.
	Catalogue number.		Use by date.
	Keep away from sunlight.		Sterilized using irradiation. Single sterile barrier system with protective packaging inside.
	Do not re-use.		Unique Device Identification.
	Do not resterilize.		Medical Device.
	Keep dry.		Text language.
	Consult instructions for use.		Do not use if package is damaged and consult instructions for use.

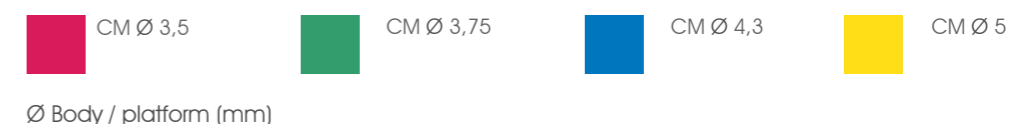

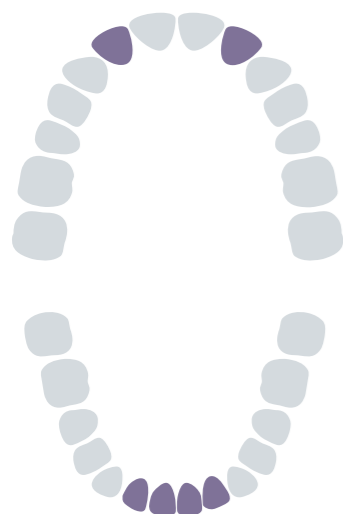

Implant diameters: Narrow platform.

- MPI Excellence® CM Ø 3,5 mm
- MPI Excellence® CM Ø 3,75 mm

Instructions for use:

For fixed, single- and multiple-unit restorations.

Recommended position:

Lateral incisors in the upper jaw, lateral incisors and central incisors in the lower jaw. For edentulous patients with 4 implants supported overdenture in the anterior and mid areas.

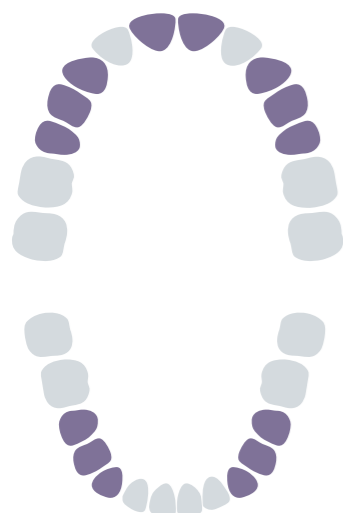

Implant diameters: Regular platform.

- MPI Excellence® CM Ø 3,75 mm
- MPI Excellence® CM Ø 4,3 mm

Instructions for use:

For fixed, single and multiple-unit restorations.

Recommended position:

Central incisors, canines and premolars in the upper jaw and canines and premolars in the lower jaw.

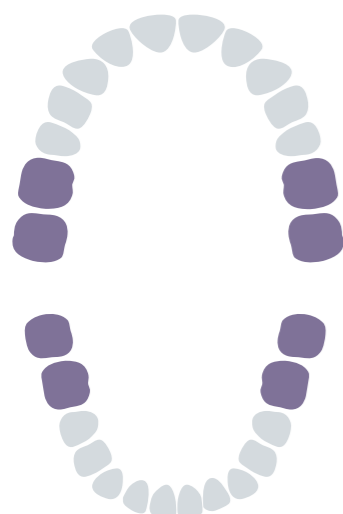

Implant diameters: Wide platform.

- MPI Excellence® CM Ø 5 mm

Instructions for use:

For fixed, single and multiple-unit restorations.

Recommended position:

Molars in both jaws.

Quality

To ensure the most demanding quality standards, we have equipped our metrology laboratory with qualified personnel and state-of-the-art measuring instruments. Thanks to demanding quality controls, we have achieved a success rate of over 99%. The "Zero defects" policy is our fundamental basis for the quality of our products and the satisfaction of our customers.

MPI is certified with:

- ISO13485:2016
- UNE166002:2021

Orders

Telephone: +34 91 684 60 63

E-mail: pedidos@mpimplants.com

Shipments and verification of the products

For orders over 150€, the products will be sent free of charge.

Once the order is received, the user should check the order and products.

If there should be any deviation in the order, please contact us as soon as possible.

Return policy

The maximum return period is 15 days from the date of issuance of the delivery note. Changes will not be accepted once the material has been opened and used or its packaging is not in perfect condition.

Payment Methods

Direct debit / cash on delivery (additional cost).

Warranty

We guarantee the replacement of our products as long as they are combined with original MPI components.



For more information:
☎ +34 916 846 063
www.mpimplants.com